

KNX® RF Transceiver Module with Embedded protocol

ADVANCE INFORMATION

This document contains information on a new product. Specifications and information herein are subject to change without notice.

Product Description

The RC1180-KNX® RF Transceiver Module is a compact surface-mounted high performance module with embedded KNX RF protocol as defined by the KNX Association (www.knx.org). The module has a UART interface for serial communication and configuration. The module is pre-certified for operation under the European radio regulations for license-free use and measures only 12.7 x 25.4 x 3.3 mm with shielding. When used with quarter-wave antennas a line-of-sight range of 500-600 meter can be achieved. The RC1180-KNX meets the KNX specification and supports S, A and E modes, and operates in the 868 MHz frequency band. The physical layer complies with the relevant parts of the EN 50090 (ISO/IEC 14543-3).

Applications

- Home and building control
- HVAC
- AMR, Automatic Meter Reading
- Gateways KNX RF/KNX-IP/KNX Twisted Pair



Features

- Embedded KNX RF protocol (KNX-RF v1.1 and KNX Ready)
- Supports unidirectional and bidirectional devices
- Binding of up to 64 other KNX-RF devices
- Listen Before Talk (LBT) to reduce collisions
- Automatic battery supervision
- Received Signal Strength Information (RSSI)
- Pin compatible with the Wireless M-Bus module RC1180-MBUS
- 12.7 x 25.4 x 3.3 mm compact module for SMD mounting
- Completely Shielded
- Wide supply voltage range, 2.0 – 3.9 V
- Ultra low power modes for extended battery lifetime
- Conforms with EU R&TTE directive (EN 300 220, EN 301 489, EN 60950)
- Confirms with EN 50090 (ISO/IEC 14543-3)
- Designed for EX compliance

Quick Reference Data

Parameter	RC1180-KNX	Unit
Frequency band	868.0 – 870.0	MHz
Nominal frequency	868.3	MHz
Number of channels*	1*	
Nominal data rate	32.768	kchip/s
Max output power	10	dBm
Sensitivity at nominal data rate (typ)	-102	dBm
Supply voltage	2.0 – 3.9	Volt
Current consumption, RX / TX	24 / 37	mA
Current consumption, SLEEP	Typ 0.3	uA
Temperature range	-40 to +85	°C

*Multiple channels available for adaptation to future specifications

Typical connection circuit

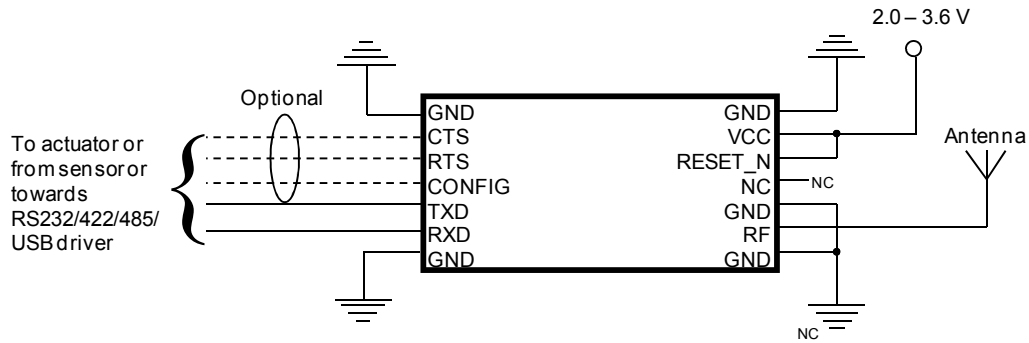

Principle of operation

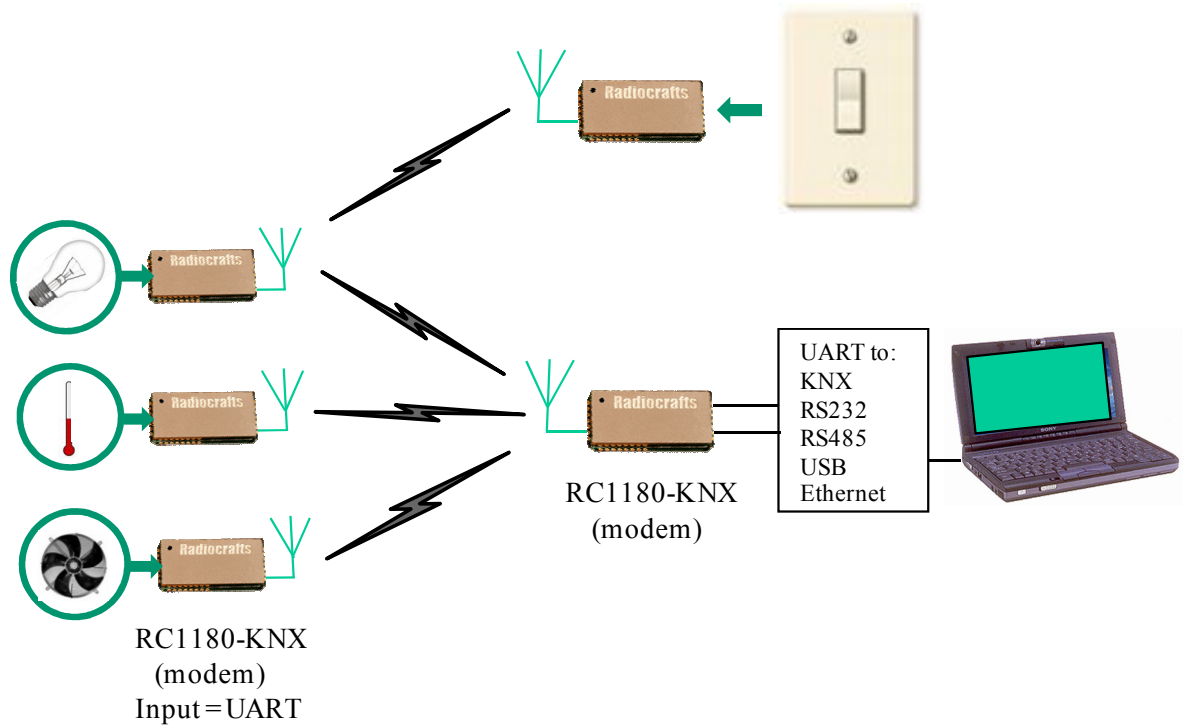

Pin Assignment

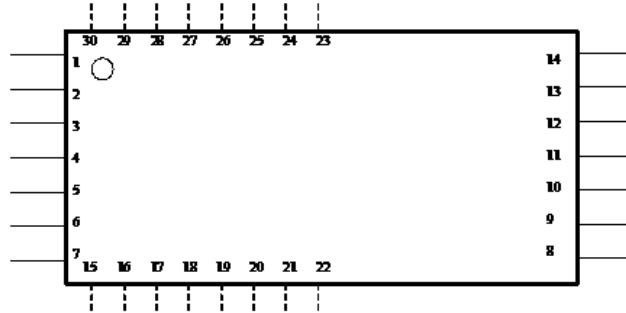

Pin Description

Pin no	Pin name	Description
1	GND	System ground
2	CTS/RXTX	UART Clear to Send
3	RTS/SLEEP	UART Request to Send
4	CONFIG	Configuration Enable. Active low.
5	TXD	UART TX Data
6	RXD	UART RX Data
7	GND	System ground
8	GND	System ground
9	RF	RF I/O connection to antenna
10	GND	System ground
11	NC	Not Connected
12	Reset	RESET_N. Active Low
13	VCC	Supply voltage input. Internally regulated.
14	GND	System ground
15-30	I/O	For future use and customer specific customized firmware, do not connect

PCB Layout Recommendations

The recommended layout pads for the module are shown in the figure below. All dimensions are in thousands of an inch (mil) and the modules outer dimensions are fixed. The circle in upper left corner is an orientation mark only, and should not be a part of the copper pattern.

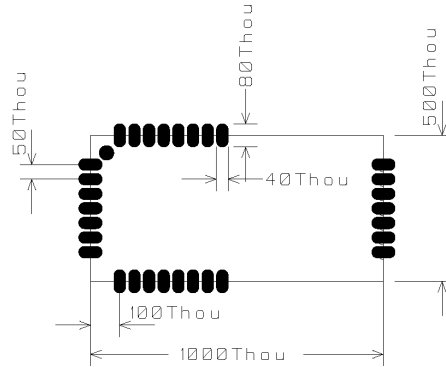

A PCB with two or more layers and with a solid ground plane in one of the inner- or bottom layer(s) is recommended. All GND-pins of the module shall be connected to this ground plane with vias with shortest possible routing, one via per GND-pin.

Mechanical Drawing

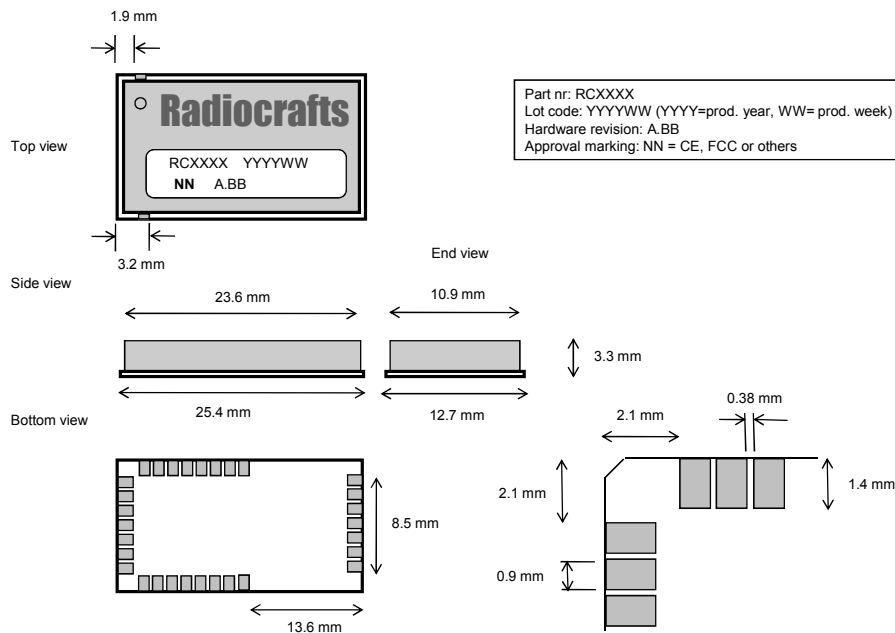

Drawings are not to scale

Mechanical Dimensions

The module size is 12.7 x 25.4 x 3.3 mm

© 2010 Radiocrafts AS. All rights reserved.

Radiocrafts AS, Sandakerveien 64, NO-0484 OSLO, NORWAY

E-mail: sales@radiocrafts.com Web site: www.radiocrafts.com

Phone: (+47) 4000 5195 Fax: (+47) 22 71 29 15